

## Model# 0084-A17

### Two Handle Cast Brass Bar/Laundry Faucet

#### FEATURES & SPECIFICATIONS

- Canopy Handles
- 4-3/32" Reach Gooseneck Rigid/Swivel Spout
- Quick-Pression Quarter-Turn Stems, Replaceable Seats
- 2 or 3-Hole 4" Installation
- 1.5 GPM Flow Rate

#### FINISHES

- PC Polished Chrome

#### STANDARDS

- ASME A112.18.1
- ANSI / NSF 61, SECTION 9
- ANSI A117.1 / ADA COMPLIANT
- CONTAINS NO MORE THAN 0.25% WEIGHTED AVERAGE LEAD CONTENT

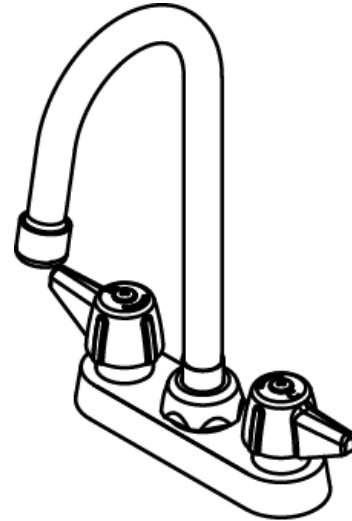

#### FLOW

- 1.5 GPM Flow Rate

#### WARRANTY

- Lifetime Limited Warranty
- Lifetime Residential Warranty
- 5 Year Commercial Warranty

Job Name \_\_\_\_\_ Date \_\_\_\_\_

Model Specified \_\_\_\_\_ QTY \_\_\_\_\_

Customer/Wholesaler \_\_\_\_\_

Contractor \_\_\_\_\_

Architect/Engineer \_\_\_\_\_

Submitted as Shown \_\_\_\_\_

Submitted w/ Variations \_\_\_\_\_

0084-A17/REV. 10 2018

Product Specifications subject to change without notice

## Model# 0084-A17

### Two Handle Cast Brass Bar/Laundry Faucet

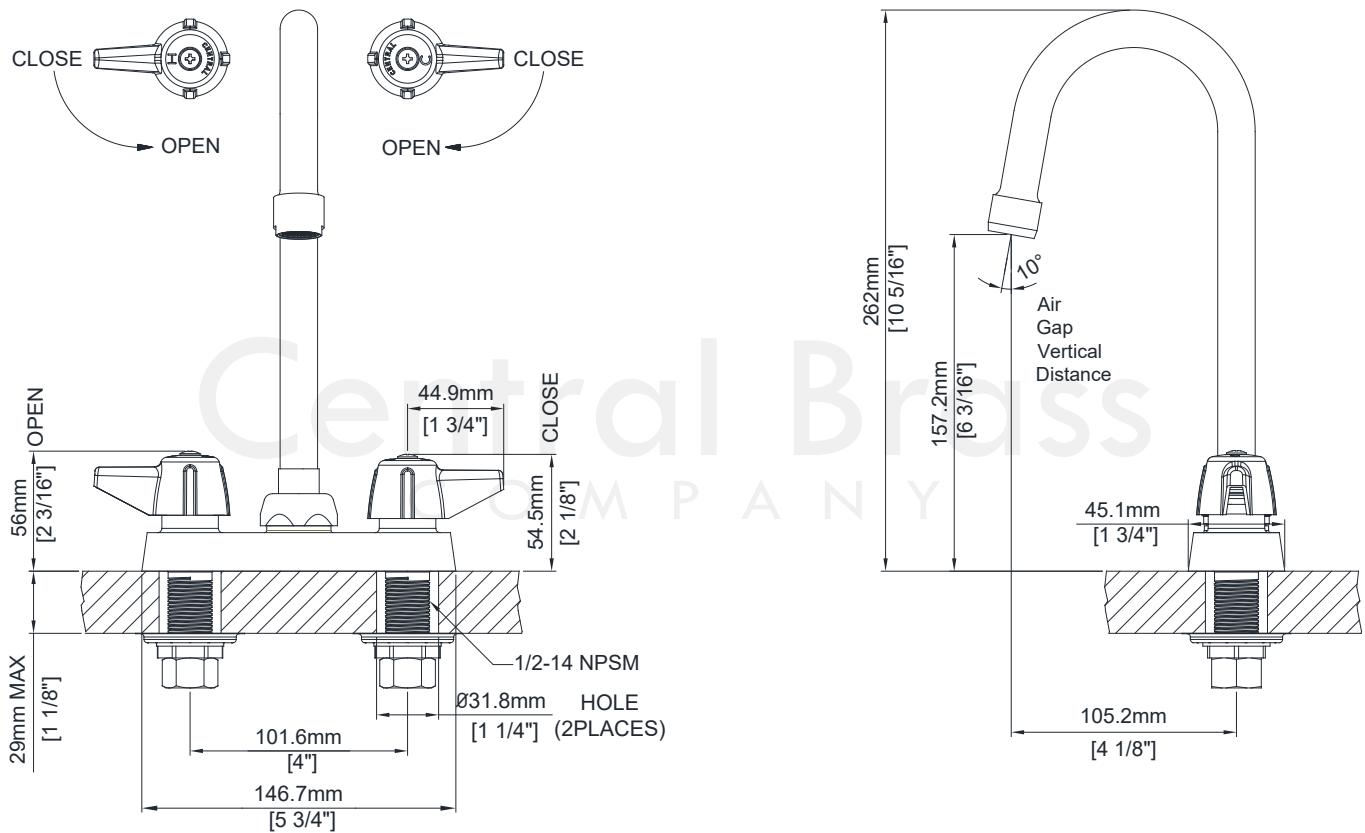

0084-A17/REV. 10 2018

Product Specifications subject to change without notice